

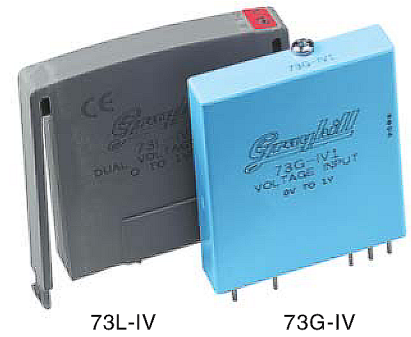

FEATURES

- Wide Variety of Input Ranges
- Standard Package and Pin-out
- Single 5V Power Supply
- 12-Bit Resolution
- Optical Isolation from Input to Output
- Intermix With Digital Modules on the Same Rack
- Meets the Requirements of IEEE 472
- UL, CSA, CE Certified (OpenLine only)



CIRCUITRY: Voltage Output

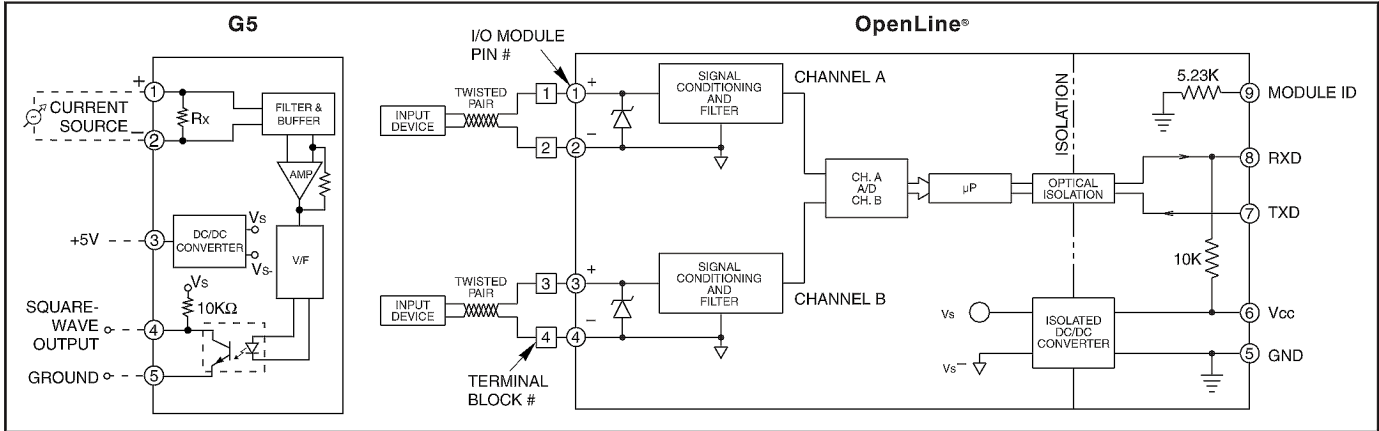

SPECIFICATIONS: By Part Number

Type/Function		Grayhill Part Number					
G5, OpenLine®		73G-IV1	73G-IV5	73G-IV10	73L-IV1	73L-IV5	73L-IV10
Specifications	Units						
Number of Inputs		1 Ch., Diff.	1 Ch., Diff.	1 Ch., Diff.	2 Ch., S.E.	2 Ch., S.E.	2 Ch., S.E.
Resolution	bits	12	12	12	12	12	12
Absolute Accuracy@25°C ^{1, 2}	μV/count	244.1	1221	2441	244.1	1221	2441
Accuracy Drift w/Temp. ²	% of full scale	+/- 0.1	+/- 0.1	+/- 0.1	0.075	0.075	0.075
Maximum Offset	PPM/°C	+/- 50	+/- 50	+/- 50	+/- 35	+/- 25	+/- 25
Maximum Gain (0-60°C)	PPM/°C	+/- 55	+/- 55	+/- 55	+/- 75	+/- 75	+/- 75
Serial Data Format		12-bit packet	12-bit packet	12-bit packet	Right Justified, 16-bit	Right Justified, 16-bit	Right Justified, 16-bit
Serial Data Packet		N/A	N/A	N/A	115.2Kb,N,8,2	115.2Kb,N,8,2	115.2Kb,N,8,2
Step Response Time ⁴	mS	2.5	2.5	2.5	1.5	1.5	1.5
Input Resistance (Rx)	Mohm	1	1	1	2.2	2.2	2.2
Input Voltage Range	Vdc	0-1	0-5	0-10	0-1	0-5	0-10
Maximum Overload	V	—	—	—	+/- 30	+/- 30	+/- 30
Logic Voltage Range	Vdc	4.5-5.5	4.5-5.5	4.5-5.5	4.75-5.25	4.75-5.25	4.75-5.25
Maximum Logic Supply Current @ 5Vdc	mA/Ch.	150	150	150	38	38	38
Module ID (Pin 9)	KΩ	N/A	N/A	N/A	5.23	5.23	5.23
Isolation Voltage							
Field to Logic	Vrms	2500	2500	2500	2500	2500	2500
Field to Power	Vrms	2500	2500	2500	2500	2500	2500
Module to Module	Vrms	2500	2500	2500	2500	2500	2500
Channel A to Channel B		—	—	—	None	None	None
Environmental Conditions							
Operating Temperature ³	°C	0 to 60	0 to 60	0 to 60	-40 to 85	-40 to 85	-40 to 85
Storage Temperature	°C	-25 to 85	-25 to 85	-25 to 85	-55 to 100	-55 to 100	-55 to 100

¹ Includes offset, gain, non-linearity and repeatability error terms.

² Accuracy and drift graphs are available in Bulletin #753.

³ Start up temperature greater than -25°C.

I/O Modules

SPECIFICATIONS: By Part Number

Type/Function		Grayhill Part Number			
G5, OpenLine®		73G-IV5B	73G-IV10B	73L-IV5B	73L-IV10B
Specifications	Units				
Number of Inputs		1 Ch., Diff.	1 Ch., Diff.	2 Ch., S.E.	2 Ch., S.E.
Resolution	bits	12	12	12	12
Absolute Accuracy @ 25°C ^{1,2}	mV/count	2.44	4.88	2.44	4.88
Accuracy Drift w/Temp. ²	% of full scale	+/-0.1	+/- 0.1	0.075	0.075
Maximum Offset	PPM/°C	+/- 50	+/- 50	+/- 25	+/- 25
Maximum Gain (0 to 60°C)	PPM/°C	+/- 55	+/- 55	+/- 75	+/- 75
Serial Data Format		12-bit packet	12-bit packet	Right Justified, 16-bit	Right Justified, 16-bit
Serial Data Packet		—	—	115.2Kb, N, 8, 2	115.2Kb, N, 8, 2
Step Response Time ³	mS	2.5	2.5	1.5	1.5
Input Resistance (Rx)	Mohm	1	1	2.2	2.2
Input Voltage Range	Vdc	-5 to 5	-10 to 10	-5 to 5	-10 to 10
Maximum Overload	V	—	—	+/- 30	+/- 30
Logic Voltage Range	Vdc	4.5-5.5	4.5-5.5	4.75-5.25	4.75-5.25
Maximum Logic Supply Current@5Vdc	mA/Ch.	150	150	38	38
Module ID (Pin 9)	KΩ	N/A	N/A	5.23	5.23
Isolation Voltage					
Field to Logic	Vrms	2500	2500	2500	2500
Field to Power	Vrms	2500	2500	2500	2500
Module to Module	Vrms	2500	2500	2500	2500
Channel A to Channel B		—	—	None	None
Environmental Conditions					
Operating Temperature	°C	0 to 60	0 to 60	-40 to 85	-40 to 85
Storage Temperature	°C	-25 to 55	-25 to 85	-55 to 100	-55 to 100

Type/Function		Grayhill Part Number			
G5, OpenLine®		73G-IV50M	73G-IV100M	73L-IV50M	73L-IV100M
Specifications	Units				
Number of Inputs		1 Ch., Diff.	1 Ch., Diff.	2 Ch., S.E.	2 Ch., S.E.
Resolution	bits	12	12	12	12
Absolute Accuracy @ 25°C ^{1,2}	μV/Count	12.2	24.4	12.2	24.4
Accuracy Drift w/Temp. ²	% of full scale	+/- 0.1	+/- 0.1	0.07	0.07
Maximum Offset	PPM/°C	+/- 50	+/- 50	+/- 35	+/- 35
Maximum Gain (0 to 60°C)	PPM/°C	+/- 55	+/- 55	+/- 75	+/- 75
Serial Data Format		12-bit packet	12-bit packet	Right Justified, 16-bit	Right Justified, 16-bit
Serial Data Packet		—	—	115.2Kb, N, 8, 2	115.2Kb, N, 8, 2
Step Response Time ³	mS	2.5	2.5	1.5	1.5
Input Resistance (Rx)	Mohm	1	1	2.2	2.2
Input Voltage Range	mV	0-50	0-100	0-50	0-100
Maximum Overload	V	—	—	+/- 30	+/- 30
Logic Voltage Range	Vdc	4.5-5.5	4.5-5.5	4.75-5.25	4.75-5.25
Maximum Logic Supply Current@5Vdc	mA/Ch.	150	150	30	30
Module ID (Pin 9)	KΩ	N/A	N/A	5.23	5.23
Isolation Voltage					
Field to Logic	Vrms	2500	2500	2500	2500
Field to Power	Vrms	2500	2500	2500	2500
Module to Module	Vrms	2500	2500	2500	2500
Channel A to Channel B		N/A	N/A	None	None
Environmental Conditions					
Operating Temperature	°C	0 to 60	0 to 60	-40 to 85	-40 to 85
Storage Temperature	°C	-25 to 85	-25 to 85	-55 to 100	-55 to 100

¹ Includes offset, gain, non-linearity and repeatability error terms.

² Accuracy and drift graphs are available in Bulletin #753.

³ Start up temperature greater than -25°C.